



WP15C-C

Industrial Panel PC



15" XGA Rugged Stainless Steel Industrial Panel PC
Intel® Bay Trail J1900 / Celeron™ 3855U



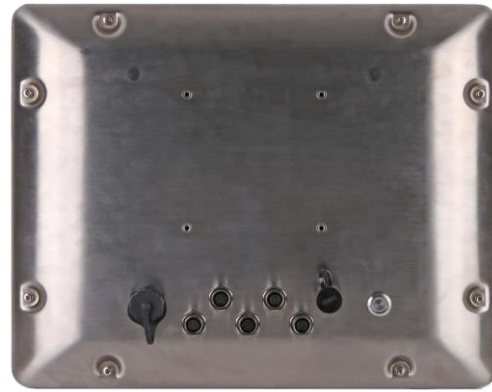

Specifications :

Processor	CPU	Intel Bay Trail J1900 / Celeron™ 3855U, clock speed 2G
	Frequency	Quad core 2GHz/1.6GHz
	L2 Cache	1MB
	Chipset	Intel® Celeron Bay Trail-M/D - Bay Trail
	Memory	1 x 204-pin SODIMM DDR3L-1333MHz support up to 8GB
	Storage Medium	1 x SATA2.0 + 1 x mSATA
I/O	LAN	2 x Intel I210 1000Mbps
	Audio	Non
	USB	2 x USB2.0
	COM	2 x RS232 (RS485 in option)
	Rear I/O	2x Mini-PCIe slot, extensible 3G, WIFI wireless card
Physical	Dimensions (W x H x D)	370mm x 294mm x 42mm
	Drill Hole Size (W x H)	Non
	NW	kg(lb)
OS	OS	Windows7, Windows8, Windows10, Linux
Power	Input Voltage	DC 12V~24V
	Maximum Power Dissipation	38.6Watt
LCD	LCD Size	15" XGA TFT (21.5" Full HD TFT in option)
	Resolution	1024 x 768 (1920 x 1080)
	Colors	16.7MB
	Active Area (W x H)	304.13mm x 228.10mm (11.97" x 8.98")
	Backlight	LED
	MTBF	30000hrs
	Pixel Pitch (H x V)	0.297 x 0.297
	Luminance	420cd/m2
	Contrast Ratio	800 : 1
Touch screen	Viewing Angle	(L) 80 / (R) 80 / (T) 80 / (B) 80
	Type	Multi-point capacitive touch screen
	Transmittance	> 75%
	Controller Interface	USB
	Driver Support	Windows 7, Windows 8, Windows 10, Linux
	Multi-touch	10 points (windows system)
Environmental	Surface Hardness	Mohs' Number 7
	Type	Multi-point capacitive touch screen
	Transmittance	> 75%
	Controller Interface	USB
	Driver Support	Windows 7, Windows 8, Windows 10, Linux
	Multi-touch	10 points (windows system)
	Surface Hardness	Mohs' Number 7
	Work Temperature	-20 ~ 60°C (14~122°F) (General temperature HDD/SSD)
	Storage Temperature	-20 ~ 70°C (-4 ~ 158°F)
	Relative Humidity	5~95% (Non Condensation)
	Shake	SSD applied: 1.5 Grms, IEC 60068-2-64, random, 5 ~ 500 Hz, 1hr/axis
	Shock	SSD applied: 10 G, IEC 60068-2-64, Half-sine wave, 11ms duration
EMC	CE/FCC Class A	
Water-proof	IP68	

Dimensions :

Unit : mm

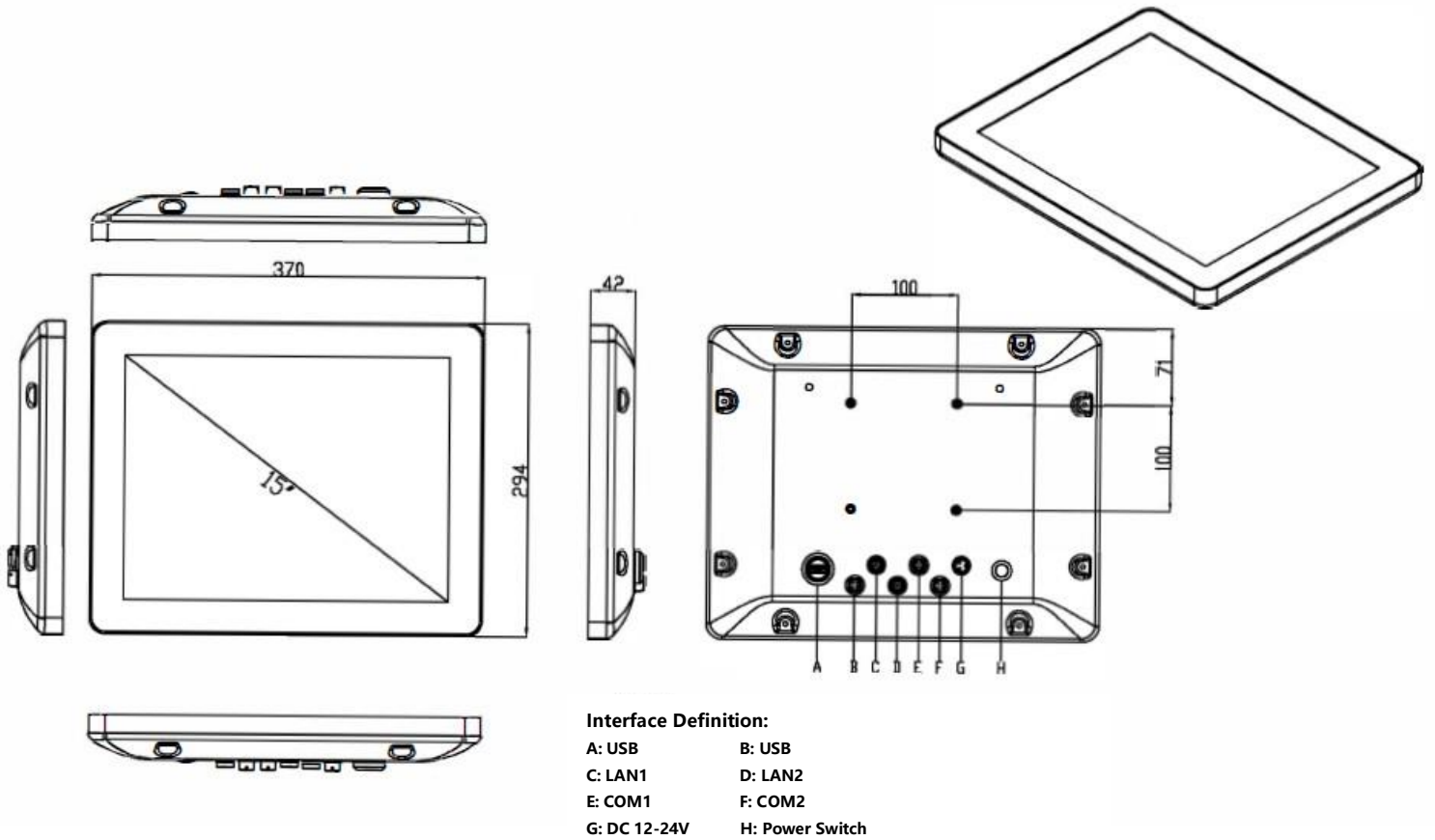

Ordering Information :

Product Code	Description
WP15C-C	15" LCD 1024*768 (optional 21.5" FHD 1920*1080)/ CPU J1900 (optional 3855U)/ No Memory/ No Hard Disk/ 2* LAN/ 2* RS232(optional RS485)/ 2USB/ Extensible WIFI&3G/ DC IN 12~24V

Optional Equipment :

Option	Description
S04-0001-002	WIFI kit (7260HMWBN) Cylindrical antennas
S04-0001-001	EC20 (4G/3G Module) MINI PCIE